



BAROMETRIC CONDENSER

OPERATION, MAINTENANCE

AND

INSTALLATION MANUAL

Graham Corporation
20 Florence Avenue
Batavia, New York 14020

OMI-BARO-1097

TABLE OF CONTENTS

SECTION I - GENERAL INFORMATION3

1.1 Introduction.....3

1.2 Design Description3

1.3 Mechanical Description (Refer to Figure III).....3

SECTION II - INSTALLATION3

2.1 Initial Inspection.....3

2.2 Installation.....4

SECTION III - OPERATION5

3.1 Startup5

3.2 Shutdown.....6

SECTION IV - TROUBLESHOOTING6

4.1 General Information.....6

SECTION V - OPERATOR’S MAINTENANCE.....6

SECTION VI - REPAIR AND REPLACEMENT ORDERS7

ATTACHMENTS

FIGURE I.....

FIGURE II.....

FIGURE III

FIGURE IV

2.2 Installation

Sufficient clearance to remove the top cover with spray device(s) should be provided above the unit for sizes 24" and smaller to allow for inspecting the internals and the spray device(s). For sizes 26" and larger, a manhole is present on the side of shell for internal inspection.

There are two (2) supports supplied on units that are 41" diameter and smaller and four (4) supports on units 42" diameter and larger. A continuous ring may be supplied in lieu of supports on fabricated units and will be supplied on fiberglass reinforced plastic units. The size of the piping for the vapor inlet, vapor outlet, condensing fluid inlet and outlet should be carefully analyzed and designed so that there are no loads (forces & moments) reacting on the condenser.

The orientation of the piping is extremely important and reference should be made to Figures II and IV for guidelines. Referring to Figure II, the table lists recommended sealed tailpipe heights for the removal of water (as the condensing fluid) under all possible operating conditions likely to be encountered. This is the minimum effective height!! This minimum height is based entirely on the maximum recorded barometric pressure, regardless of the contemplated operating pressure. For fluids other than water, further adjustments must be made to the minimum height.

Refer to Sketch A of Figure IV: If the vapor inlet piping rises vertically upward from the process vessel and goes directly into the condenser with a 90 degree elbow, the condensing fluid may flow down this pipe. Therefore, a dam or series of elbows should be installed so this will not occur. CAUTION: The dam will cause a reduction in pipe flow area -- therefore, a larger pipe may be necessary.

Refer to Sketch B of Figure IV: The vapor inlet and outlet piping are vulnerable for vapors to condense in these lines and, therefore, loops should be avoided.

Refer to Sketch C of Figure IV: The tailpipe arrangement is very crucial and should not contain any horizontal runs. The ideal is straight down and the acceptable is 45-degree minimum off the horizontal, and the change in direction must be 5 pipe diameters or 4 feet minimum away from the water outlet flange and between all changes in direction.

Refer to Sketch D of Figure IV: The recommended tailpipe seal and clearance dimensions, from the tailpipe outlet to the bottom of the hotwell is shown. The size of the hotwell shall be such that the volume of the water measured from the bottom of the tailpipe to the point of overflow is at least equal to 1.5 times the volume of the minimum recommended height of the tailpipe; in no case should the seal height be less than 12".

SECTION VI - REPAIR AND REPLACEMENT ORDERS

When it is necessary to obtain spare parts, please address your communication to:

GRAHAM CORPORATION
20 Florence Avenue
Batavia, New York 14020

| | |
|--------------|---------------------------------------------|
| Telephone: | 716 / 343-2216 |
| Spare Parts: | 800 / 828-8150 |
| Fax: | 716 / 343-1097 |
| E-MAIL: | equipment@graham-mfg.com |
| WEBSITE: | 716 / 343mw/RN TD -ra-iTj ev20 Flor11dnhNT: |

FIGURE I

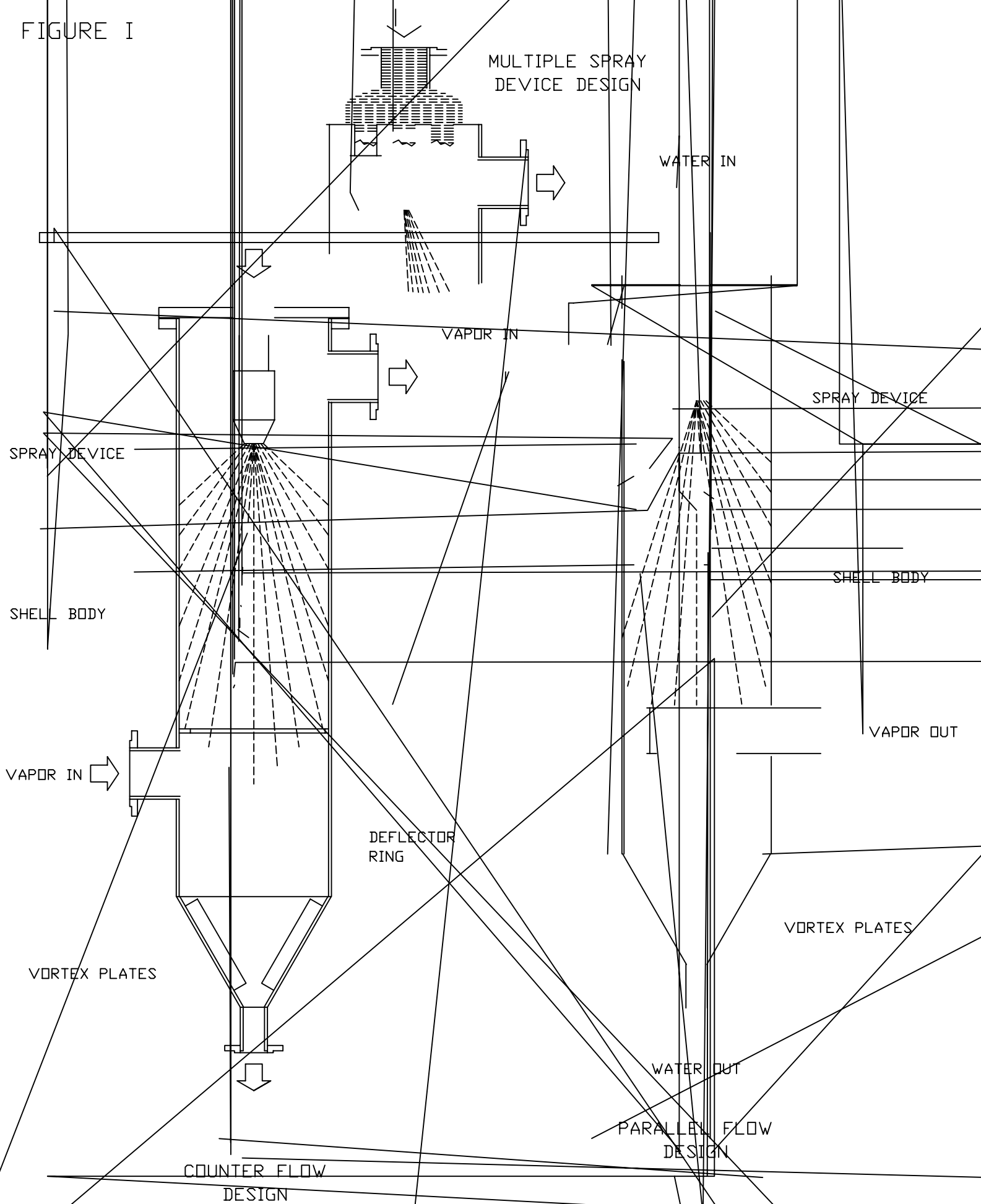

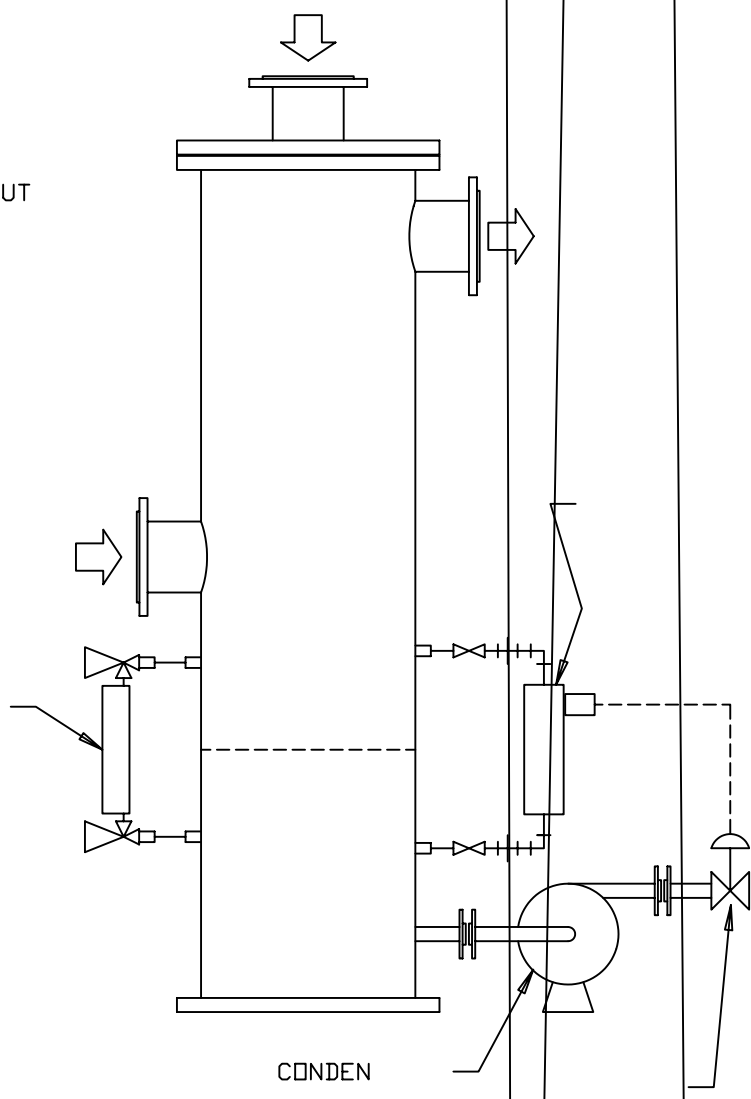
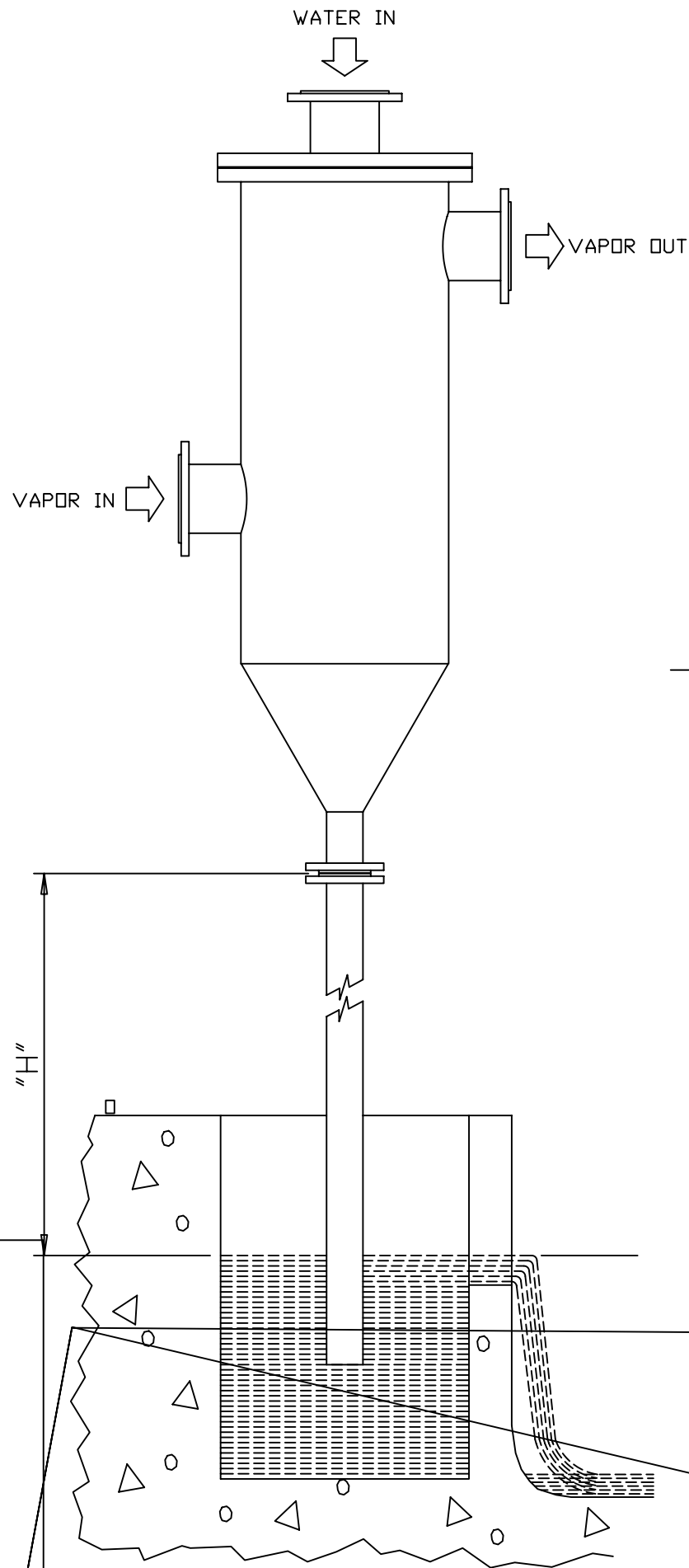

| METRIC PRESSURE INCHES OF MERCURY @ 32°F | "H" HEIGHT IN FEET (WAT) |
|------------------------------------------------|--------------------------------|
| | |

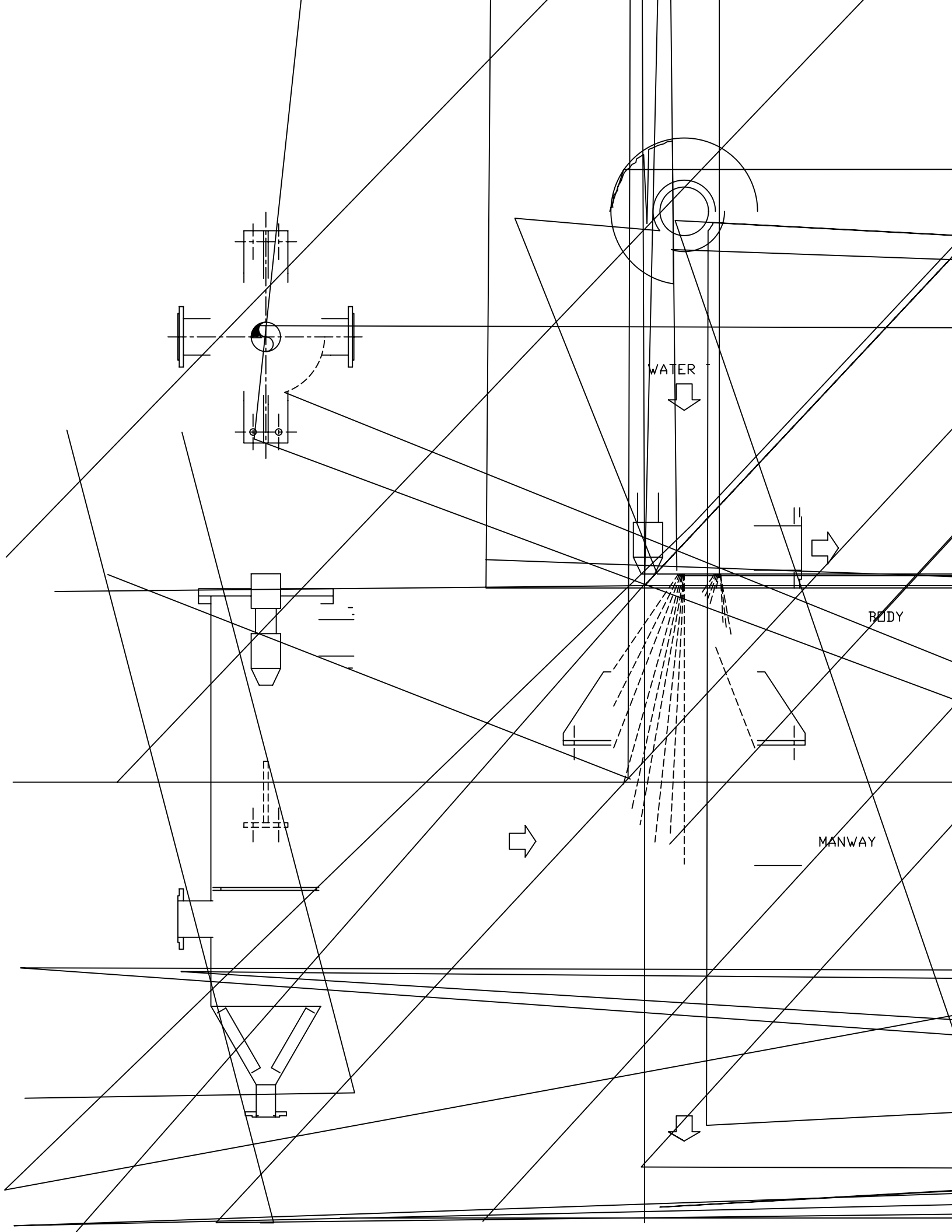

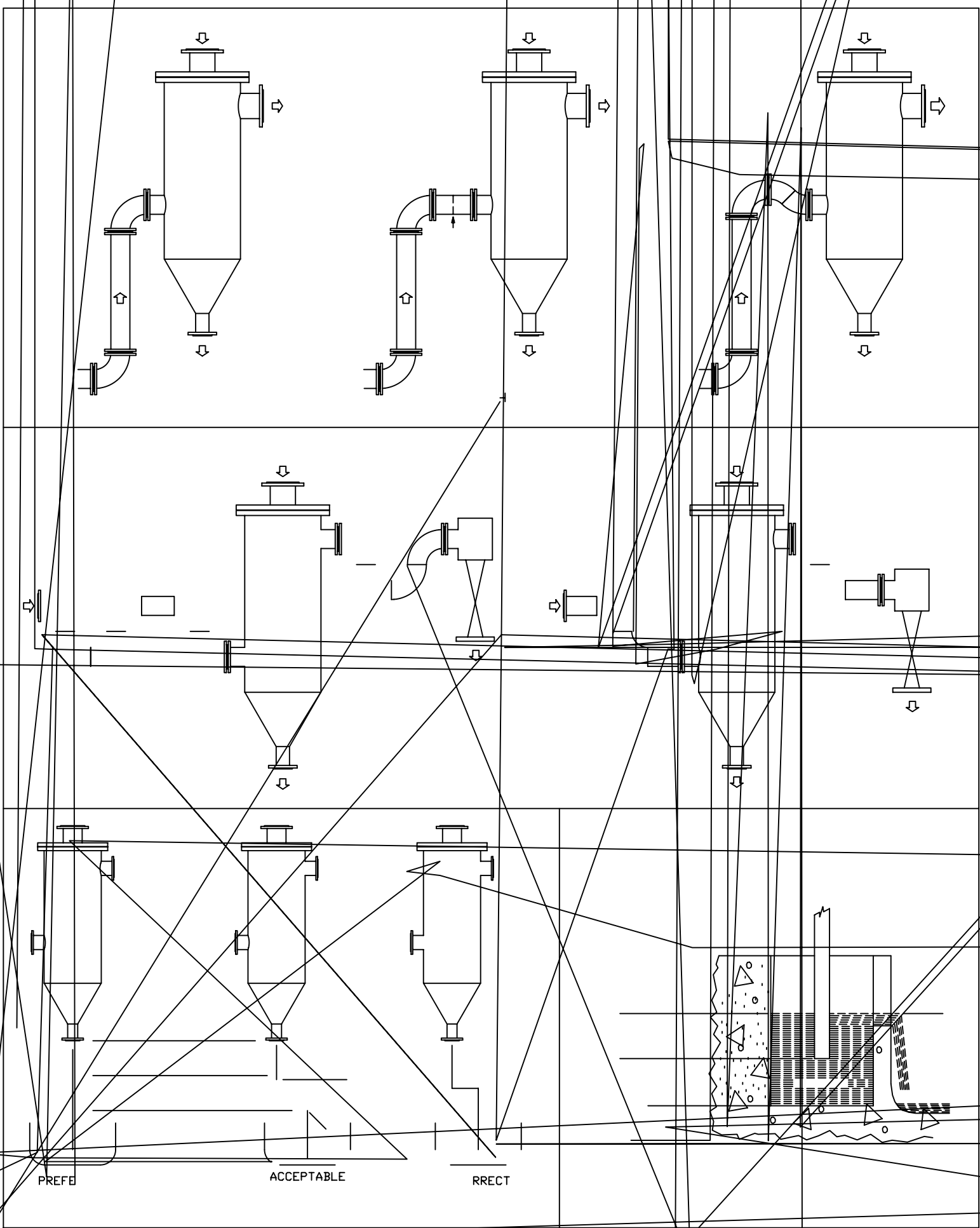

PREFE

ACCEPTABLE

RRECT